

36 WAYS TO MAKE YOUR  
SHORT RUN STAMPING  
MORE ECONOMICAL

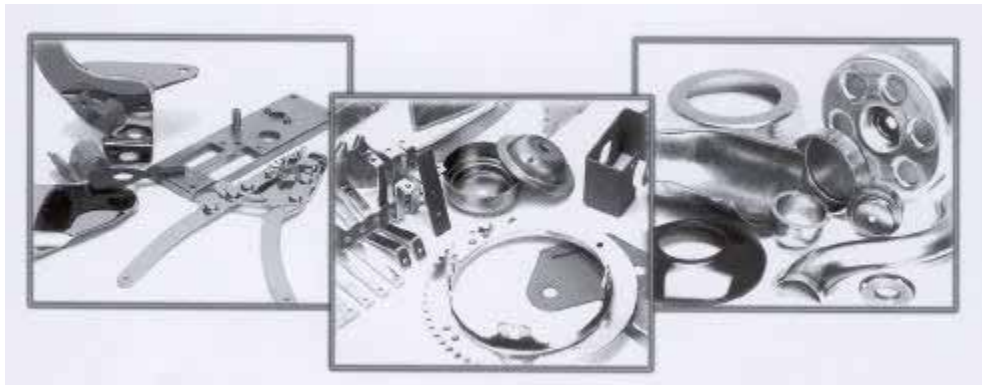

# BUYER'S GUIDE TO CONTROLLED TOLERANCE STAMPINGS



7<sup>TH</sup> EDITION

# Wrico Controlled Tolerance Stampings... ...There Is A Difference!

## Wrico Does It Better

A privately owned and operated business for over 30 years, Wrico is recognized nationally as the leader in Quality stampings and superior Customer service.

Adhering to an organizational perspective that focuses on exceeding Customer expectations, Wrico has expanded to six full service manufacturing facilities strategically located throughout the United States. Wrico supplies high quality component parts and precision assemblies to the nation's leading OEM manufacturers in the hardware, electronics, appliance, automotive, lawn & garden, and recreational vehicle industries.

Whatever your particular stamping requirements may be--large, medium, or small--Wrico can blank, pierce, form, deburr, weld, stake, fasten, plate, and paint to your specifications on parts up to 48" x 96" and 1/2" thick.

The contents of this booklet are intended to help you understand, design and buy metal stampings more efficiently and economically. It does not contain all answers to all questions but rather basic rules of thumb Wrico has found to be important in making a wise, informed short run stamping buy.

This booklet is one of many special Wrico services, including seminars, plant tours, product evaluations and studies, to help you with your stamping needs.

Wrico always welcomes your questions and comments as a means to improve its service to you, the customer.





## Contents

Business Philosophy – Wrico.....	2	Specifying Internal Tabs .....	8
Contents .....	3	Specifying Bends .....	9
When to Use Wrico Stampings .....	4, 5	Bending .....	9
36 Ways to Make... ..		Countersinking .....	10
Blanking Operations .....	6	Extrusions .....	11
Corners .....	6	Embossed Stampings .....	11
Notches .....	6	Burr Removal .....	11
Specifying Cutoffs .....	7	Flatness .....	11
Specifying Holes .....	7	Surface Finish .....	11
Notches May Be Hole Substitute.....	8		

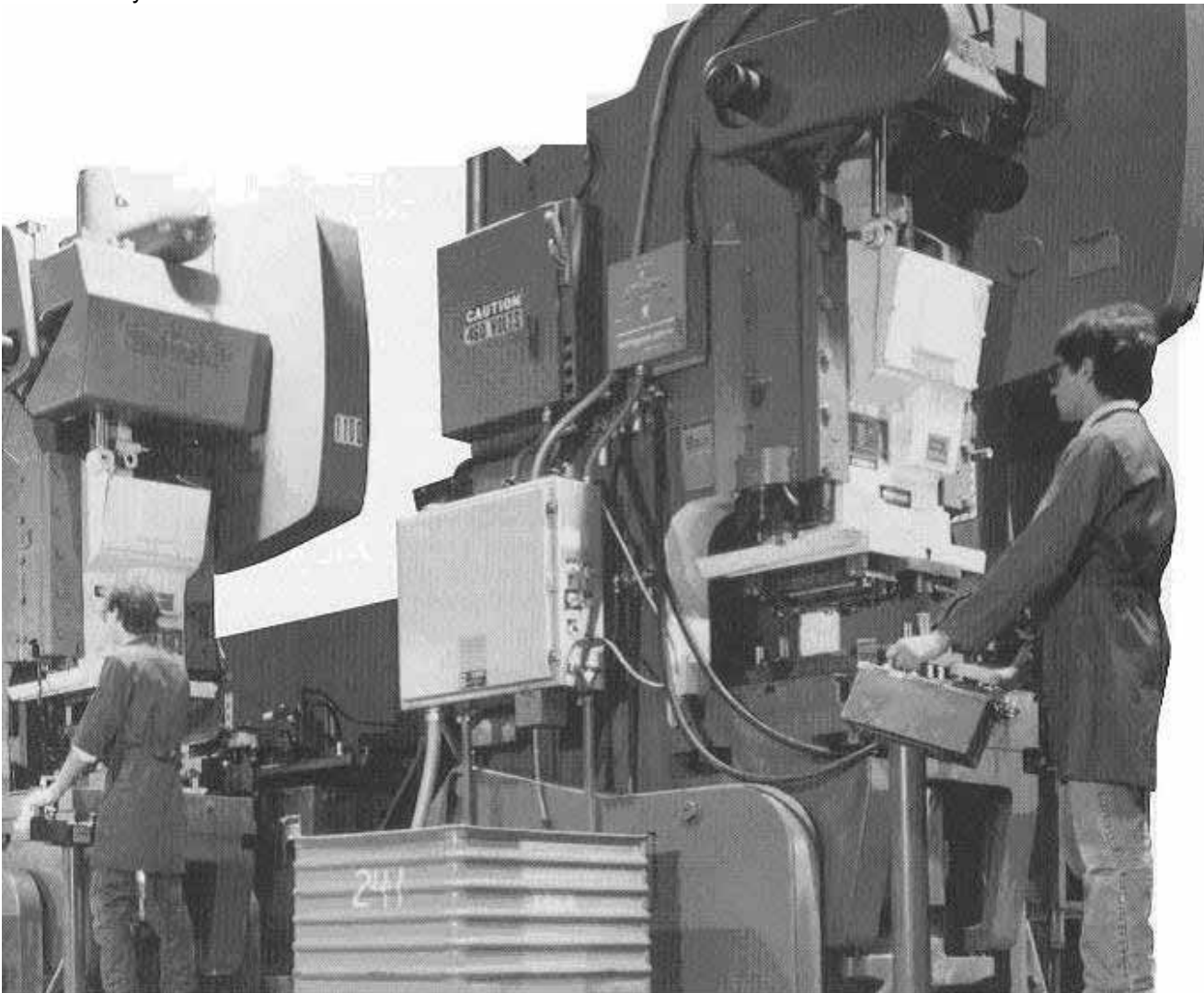

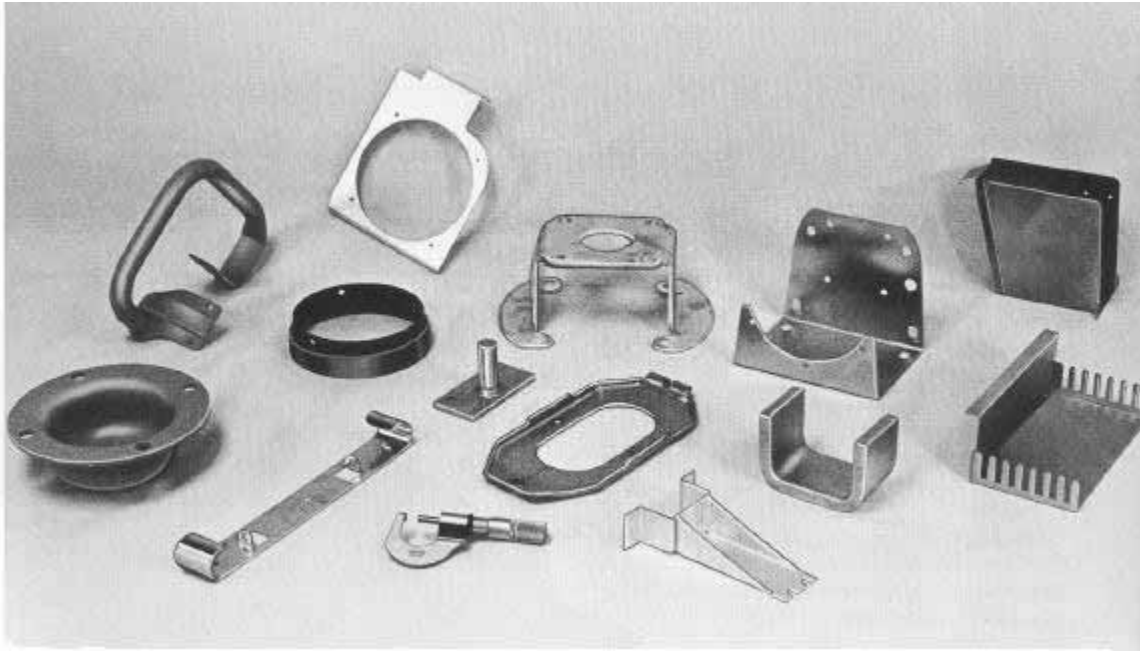

## When to Use Wrico for Short-Medium Run Stamping

Wrico makes tooling in a fraction of the time required for permanent tooling. From the estimate to the delivery, the latest technology and equipment are utilized to meet your quality, low cost, fast turnaround production requirements.

Wrico's skilled Tool Makers and Engineers assist you in developing an appropriated part design by using CAD systems, special punches, dies and existing fixtures from our extensive stock tool library. This process eliminates the time-consuming mounting and assembly requirements. Quality stampings are produced and commercially accepted tolerances are maintained--Closer tolerances can be maintained when needed.

### Save Money

Wrico can save you up to 80% on the extremely low initial tooling costs compared to permanent dies. You can save additional money each time you modify the die since it can usually be altered at a fraction of the cost of the original short run tooling. Your Inventory requirements on these stampings can be kept at an absolute minimum as they can be produced and shipped to you JIT>

Our exclusive processes and technologies are designed to save the Customer money.

### New Products

It's only logical to use less expensive, more quickly produced Wrico short run stampings on new products. Their function and appearance can be thoroughly studied before going into full production.

### Market-Testing Products

Both new and modified products may be produced inexpensively and quickly for all types of tests, trade fairs, sales meetings, etc. No need to commit or freeze-in to full production.

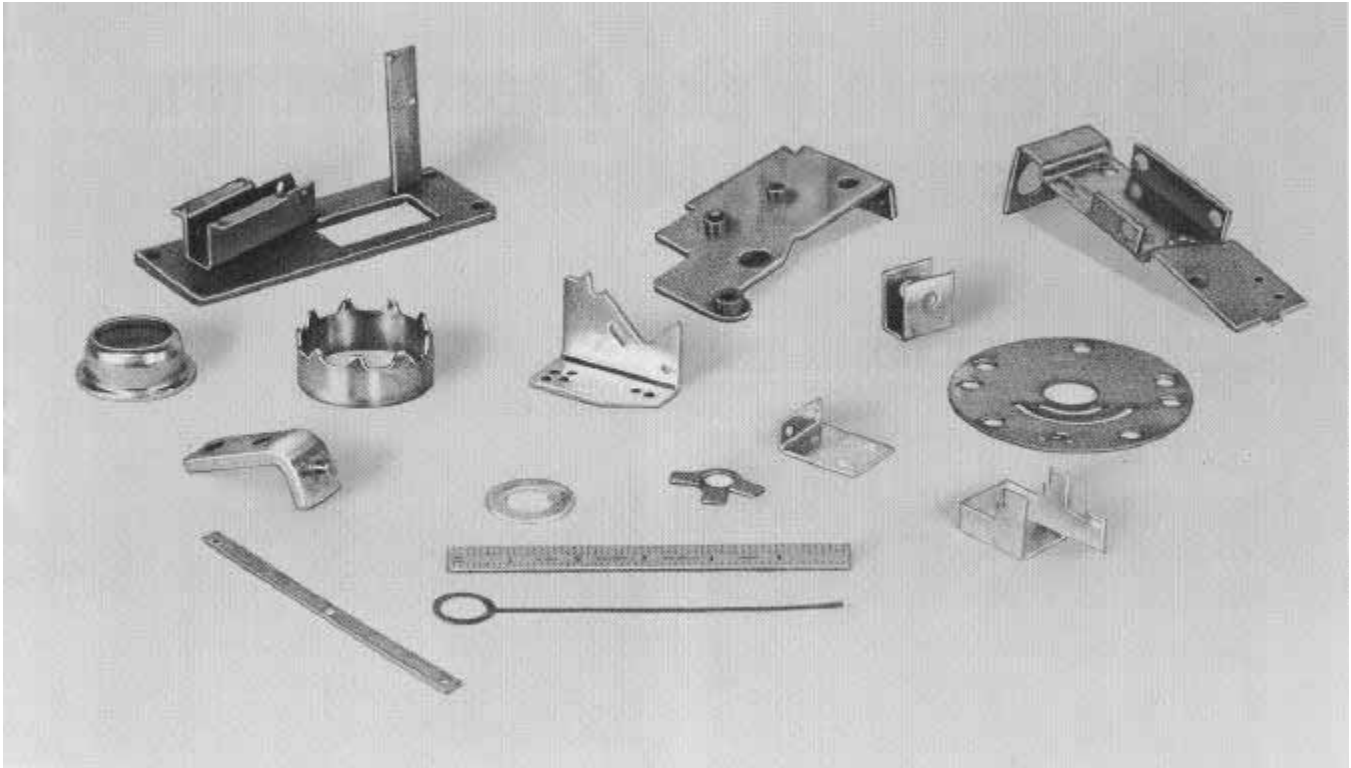

### **Modifying Products**

New product features can be made and checked quickly with Wrico Short Run Stampings.

### **Pilot Runs**

Standardized parts can be produced using the Wrico Short Run Method to advantage over conventional dies and production techniques and at far less cost and time requirements.

### **Small But Important Markets**

Low volume production runs can be made profitable to you by using short run stampings, yet quality will be up to commercial standards.

### **Experimental Study**

Product performance can be more accurately studied using actual stampings than handmade parts. Stampings have consistent tolerances and finish characteristics for best overall product evaluation.

### **Replacement Parts**

Short run stampings can "save the day" on damaged equipment when replacement parts are obsolete or out of stock.

### **Improve Time Schedules**

When a manufacturer is short of time, Wrico short run stampings can help. A good way to get needed parts while permanent tooling is being made. Use Wrico as a backup source to shortcut possible delays or production breakdowns.

### **Substitute to Your Own Production**

Wrico short run stampings can be a better answer than setting up your own production. Tool costs are low. Deliveries fast. You may even cut your own personnel and inventory requirements.

# 36 Ways to Make Short-Medium Run Stampings More Economical

## Introduction

The basic design of a particular stamping is important to its cost. The savings in time and money on a stamping depends on many factors relating to materials, quantities, tolerances and its overall general design.

To make your stampings as functional, efficient and economical as possible, the following guidelines are recommended.

## BLANKING OPERATION

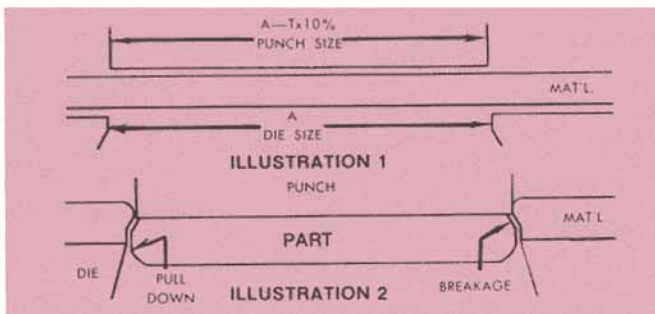

Blanking of parts, by punch press operations, necessitates a punch and die combination, conforming to the part periphery. This operation requires clearance between the punch and die. (See Illustration 1.) This clearance causes the punch to "cut" through a portion of the material, and "break" through the balance of the material thickness. (See Illustration 2.)

The punch as it enters the material, actually begins to "form" the surface of the material, prior to cutting. This "form" is referred to as pull-down. (See Illustration 2.)

## PULL-DOWN

The amount of pull-down is affected by three principal factors:

- Temper of material. The softer the material, the greater the amount of pull-down.
- Structure of material. Longer grained materials (i.e. Copper, Stainless Steel, etc.) will tend to flow, and will have a greater amount of pull-down.
- Thickness. Thicker materials pull down considerably more than thinner materials.

## BREAKAGE

The amount of breakage occurring is affected by two principal factors:

- Temper of material. As hardness increases (either by rolling or by heat treating) the amount of breakage increases.
- Structure of material. Short grained materials (i.e. Aluminum, high carbon steels, etc.) will have a greater percentage of breakage.

## Blank Design

### MINIMUM BLANK SECTIONS

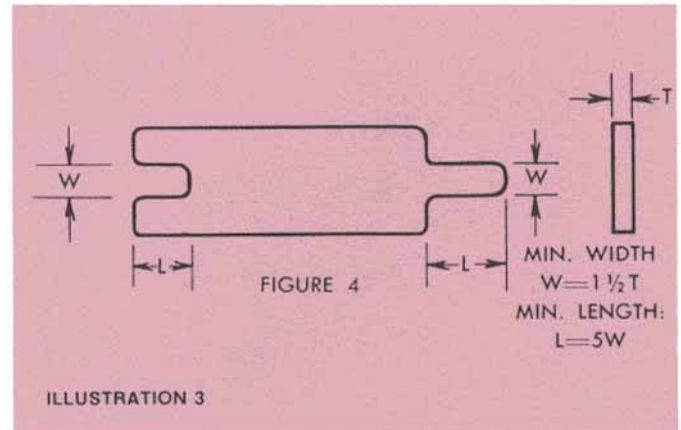

Minimum practical section "W" should never be less than 1 1/2 to 2 times material thickness in width and never less than 1/32". Length of min. section should not be greater than 5 times width of section. (See Illustration 3.)

## CORNERS

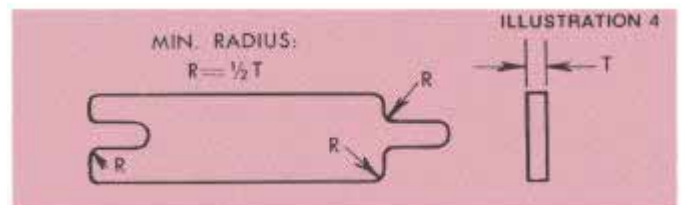

Corner radii should be a minimum of one half of the material thickness. Corners can be sharp, if the material thickness is 1/16" or less. (See Illustration 4.)

## NOTCHES

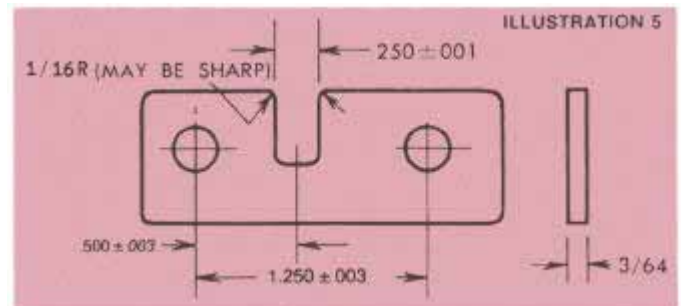

Should a notch require close size and/or location tolerances, give an option on the corner radii. (See Illustration 5.) If included in the

blank, maximum radius would be used. If included in a separate operation, a sharp corner would be required.

## SPECIFYING CUTOFFS

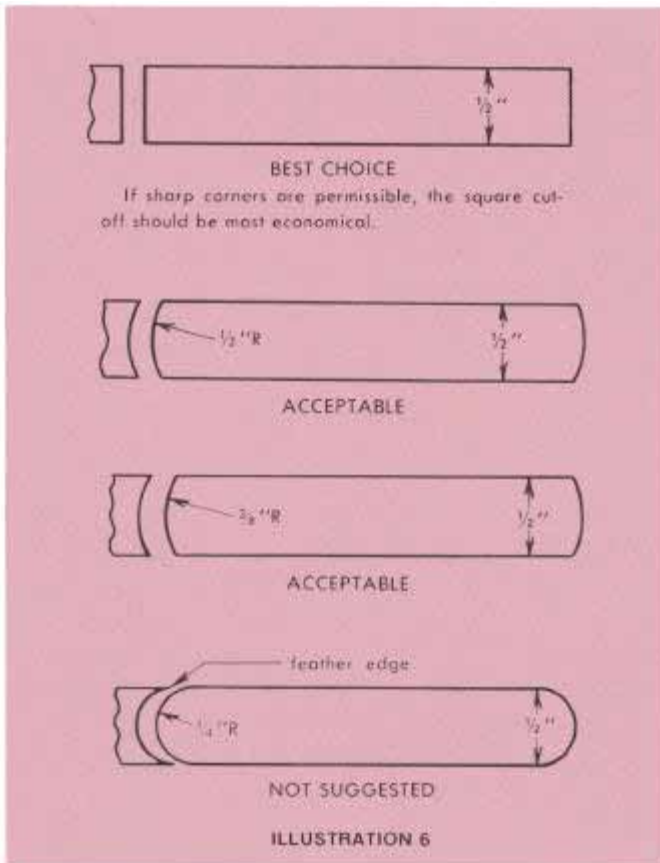

Once the material blank has been sheared to correct width, there are several correct cutoffs to specify for economical stampings. (See Illustration 6.)

## SPECIFYING HOLES – MINIMUM DIAMETERS

For general economy, remember this rule of thumb: hole diameter should be equal to or greater than the stock thickness. Holes less than stock thickness may be punched in soft aluminum or other soft materials, with the recommended minimum diameter increasing in direct ratio to the shear strength. Stainless steel usually requires a diameter equal to two times stock thickness.

If the hole diameter is less than material thickness, (or less than .050 dia.) it must be drilled and the burr removed at added cost.

## HOLE TOLERANCES

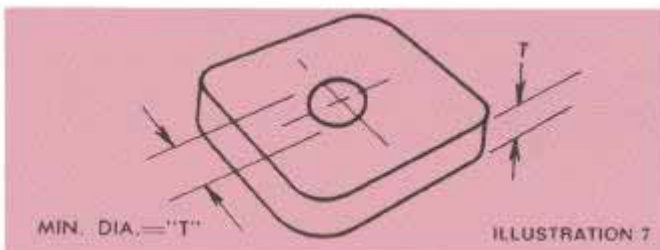

Unless specified, tolerances shown on hole diameters are considered to apply to the punch side only. (See Illustration 7.)

Breakage occurs in all punched holes. (See Illustration 8.) This is due to the clearance between the punch and die. Breakage occurs with all materials and varies by material characteristics.

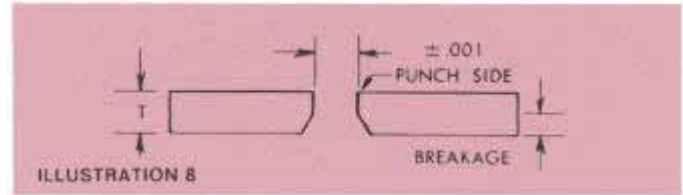

Smoothly finished holes add cost. Should they be required, the hole can be punched smaller than required, then reamed to its finished diameter. (See Illustration 8.)

## SPECIFY HOLES AND OTHER OPENINGS NEAR BLANK EDGE



The hole can be punched without causing a bulge if the web is a minimum of 1-1/2 the stock thickness. (See Illustration 9.)

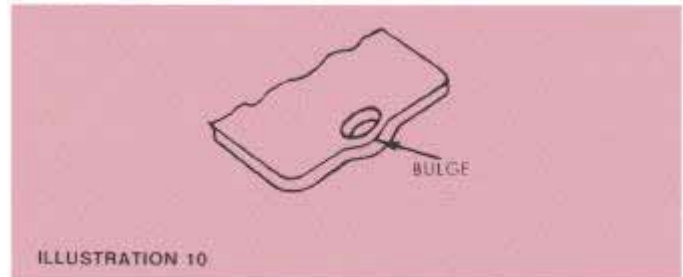

A bulge in the blank will result anytime the web is less than 1 1/2 times the stock thickness. (See Illustration 10.)



Bulge conditions increase progressively as the web decreases, until there would be a complete break-through. The bulge is hardly visible until the web is reduced to less than 1/2 the stock thickness. These examples would also apply to a web between holes.

If some bulge is not permitted, a drilling and deburring operation may be necessary. This will add to your stamping costs. (See Illustration 11.)

As a suggestion, if the web is too narrow, the profile of the blank could be changed by adding an ear of sufficient dimensions and shape to eliminate the problem.

## NOTCHES MAY BE HOLE SUBSTITUTE



ILLUSTRATION 12

Another suggestion would be to change the contour of the blank to include the hole as a notch that could be punched (See Illustration 12.) or the notch can be made wide enough so it could be included in the blank without a punching or notching operation.

## SPECIFYING HOLES AND OPENINGS NEAR BENDS

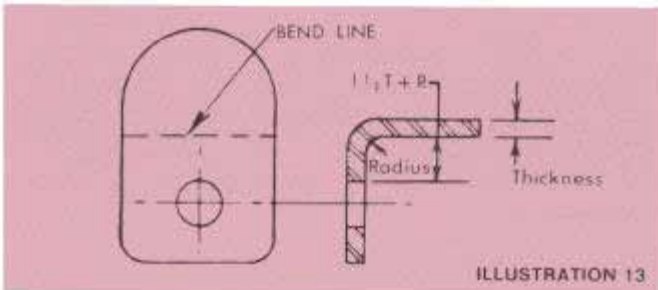

ILLUSTRATION 13

The minimum inside distance required from the edge of a hole to a bend is 1 1/2 times the material thickness plus the bend radius. (See Illustration 13.)

Distortion will result when punching the hole at a location less than the minimum distance required. If distortion is not acceptable, the hole must be punched after forming, in a separate operation. This will increase your stamping costs.

For economical stamping production, the following guidelines should be considered.

## MINIMUM REQUIREMENTS

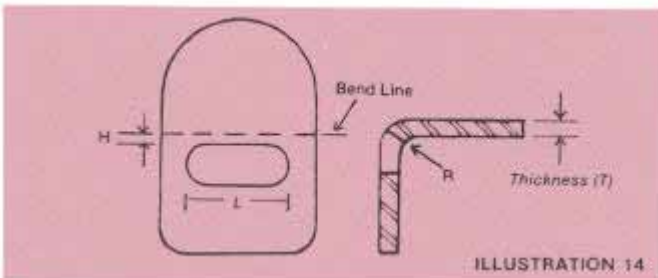

ILLUSTRATION 14

- When "L" is up to 1", "H" = 2T + R
- When "L" is 1" to 2", "H" = 2 1/2T + R
- When "L" is 2" or more, "H" = 3T to 3 1/2T + R

The function of these holes or openings should determine the degree of simplicity or complexity of tooling and operation. Be sure you give complete information for the most economical price.

## SPECIFYING INTERNAL TABS

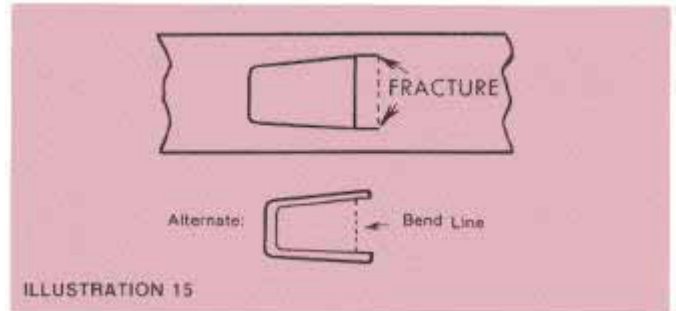

ILLUSTRATION 15

Careful analysis of your tab needs can hold your stamping costs down. A slot can be punched around the entire tab to permit bend relief. However, this requires an additional operation. If other punched openings are required, this relief slot can be punched at the same time. (See Illustration 15.)

## SPECIFYING BENDS

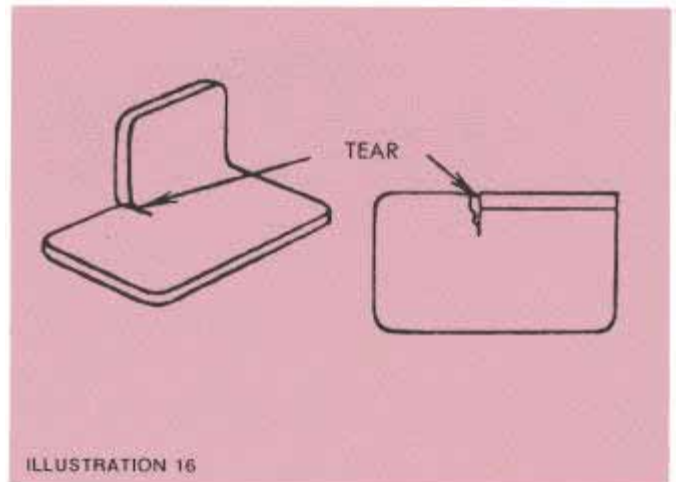

ILLUSTRATION 16

It is necessary to take special care in designing bends in your stamping to avoid material tearing. To avoid this, design the blank profile to allow offset relief where possible. If the part is under stress, this tear will likely cause fatigue failure. Stock tooling cannot be adapted because the flat area adjacent to the form must be held in position during forming. This will increase your stamping expense. (See Illustration 16.)

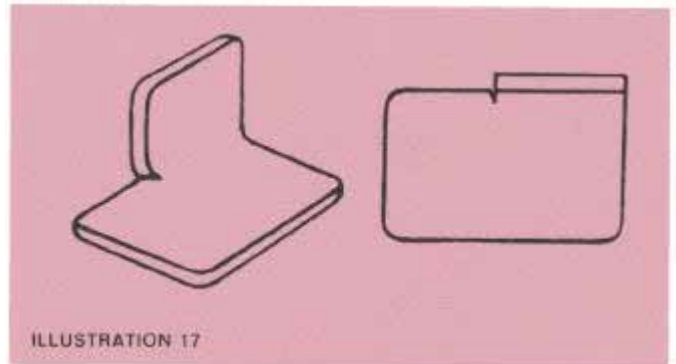
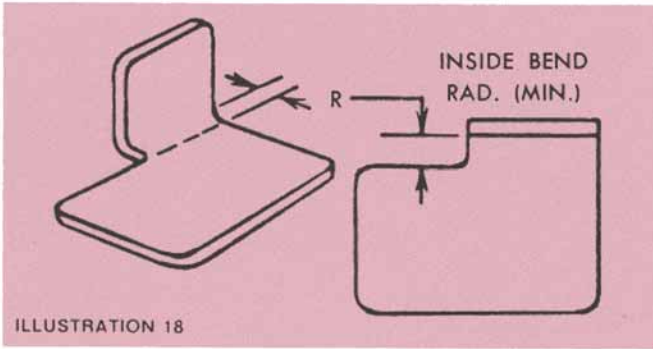

ILLUSTRATION 17

A similar case exists in Illustration 17. The form is just outside the blank profile. The tear itself runs into the center of the required bend radius.

# SPECIFYING BENDS



Solution to the tear is illustrated (18 and 19) by changing the blank profile which provides relief for the bend. This eliminates fatigue under stress and it is then possible to use Stock 90 degree punches and dies. The result is higher quality and a lower tool/engineering price.

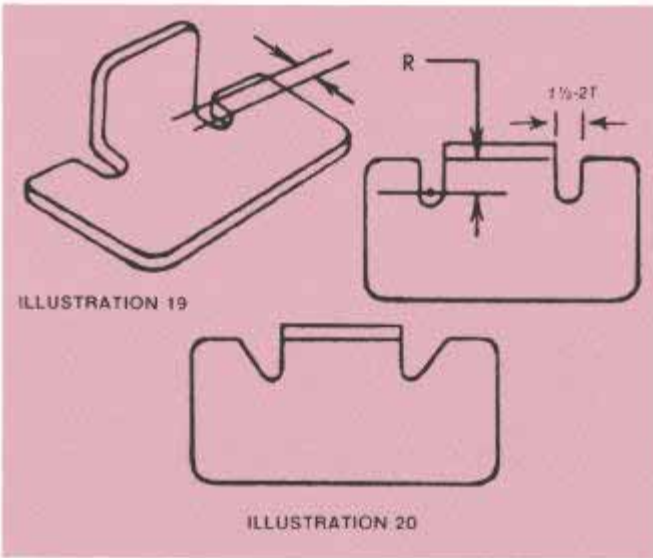

Relief notch width in the above illustrations should be at least 1/2 to 2 times the material thickness. If designed as the relief in Illustration 19, they can be included in the blanking operation at very little or no extra cost for tools.

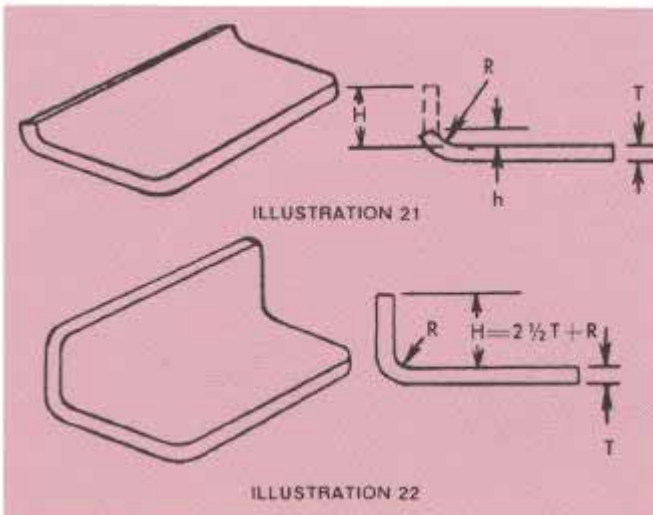

Problem forming is shown in Illustration 21. A 90 degree bend is made with insufficient material height to form right.

Therefore, sufficient material must be added so the form is high enough (H) and then trimmed. This is an extra operation which means added stamping costs.

A good rule of thumb to follow (See Illustration 22.) in allowing material for bends -determine the inside height "H" which in this case equals 2 1/2 times the material thickness (T) plus the required bend radius (R) for economical tooling and production.

This guideline is reproduced in chart form below. These recommended minimum formed height dimensions are approximate. They cover most variables of design, size, material types, tempers and thicknesses and still permit the most economical tooling and production. Easily formed materials such as Aluminum, Brass, Copper and Mild Steel may be formed with approximately 20% lower minimum inside formed height.

MINIMUM INSIDE HEIGHT OF FORM "H"					
"T"	INSIDE BEND RADIUS				
Stock Thickness	Sharp "R"	1/32 "R"	1/16 "R"	3/32 "R"	1/8 "R"
1/32	5/64	7/64	9/64	11/64	13/64
1/16	5/32	3/16	7/32	1/4	9/32
3/32	15/64	17/64	19/64	21/64	23/64
1/8	5/16	11/32	3/8	13/32	7/16
5/32	25/64	27/64	29/64	31/64	33/64
3/16	15/32	1/2	17/32	9/16	19/32

# BENDING

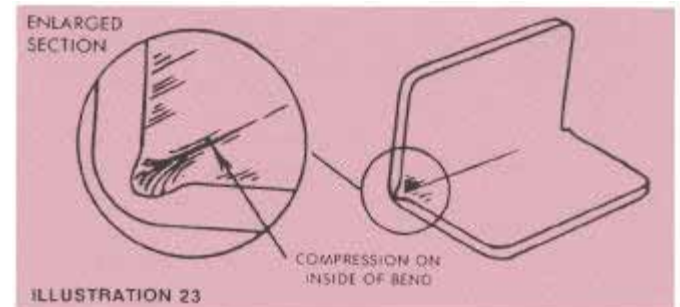

A distorted condition that occurs in forming is shown in Illustrations 23 and 24. It is a particularly noticeable distortion when heavy material is bent with a sharp inside bend radius. It is hardly noticeable on material thicknesses less than 1/16" or when the inside forming radius is large in comparison to the material thickness.

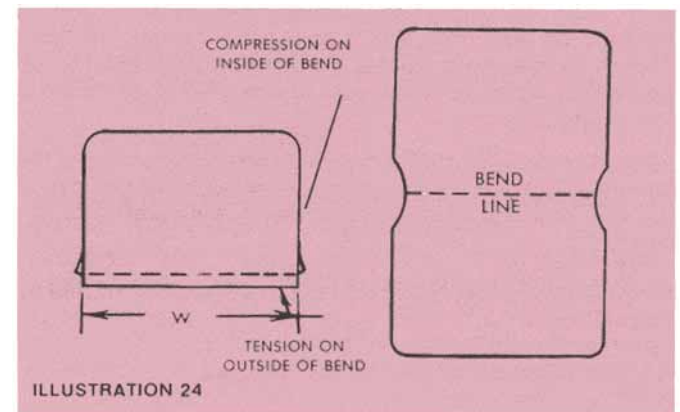

Material on the inside of the bend is under compression which results in this bulge condition on the edges. The edges on the outside of the bend are under tension and tend to pull in.

Such a bulge or distorted condition is usually of no concern and is accepted as standard practice. But, if this bulging will cause any interference with a mating part, then this should be referred to on the print so a secondary operation can be considered to remove the interference. This extra operation will add to the cost of the stamping.

If width dimension (W) must be held across the form, indicate this condition by showing relief notches. (See Illustration 24).

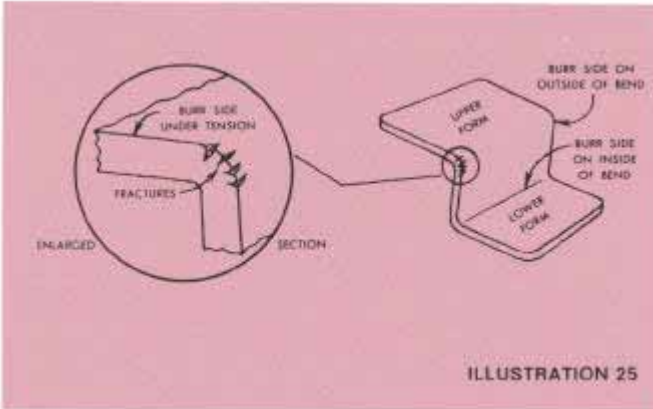

The enlarged section in Illustration 25 indicates a fracture condition that occurs when the burr side of the blank is on the outside of the bend. This would be particularly noticeable when heavy material is formed with a sharp inside bend radius. It is hardly noticeable on material thicknesses of less than 1/16" or when the inside forming radius is large enough in comparison to the material thickness, type and temper.

This fracture condition occurs because the burr side of the blank on the outside of the bend is under tension, and causes the minute fracture on the sharp edge to open up and in extreme cases, become visible.

A blank is usually produced so the burr side will be on the inside of the bend which is under compression like the lower form. However, when print requirements prevent this, or when a bend is in an opposite direction, like the upper form, fractures may occur.

Tumbling or deburring before forming can minimize the fracture in most cases. On extra heavy material with a very sharp inside bend radius, or on materials difficult to form, such as SAE 4130, tumbling well before forming may not be adequate and it may be necessary to hand file, or disc sand a radius on the sharp edges. Such secondary operations will add to the cost of production to varying degrees.

Therefore, for the most economical production, where the design will permit, designate ample inside bend radii when the burr side of the blank must be on the outside of the bend.

When slight fractures are permissible, the print should be so marked.

Any tempered aluminum alloys necessitate much larger bend radii than steel alloys do.

## SPECIFYING COUNTERSINKING

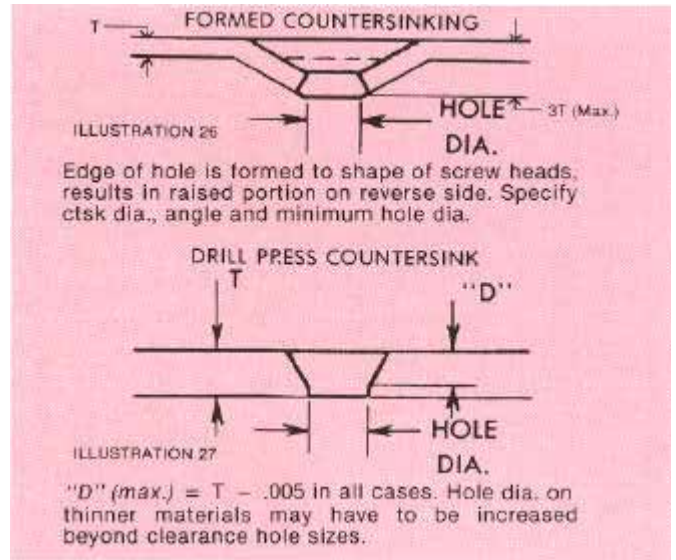

There are two types of countersinking shown above. (See Illustration 26 and 27.) Method specified is governed by the particular application. Formed countersinking is the stronger of the two methods and usually the most economical.

## SPOT WELD TIPS

When welding a flange to the main body of the part, the minimum width of the flange should be 1/2" in order to secure a good weld. Flanges of less than 1/2" require special tips and do not always yield the strongest weld.



## DIMENSIONING

Whenever dimensioning to a form the dimensions should be given to the inside of the material whenever possible. This precludes the variation in material thickness affecting the dimension and robbing the manufacturer of tolerance. This is especially true on a drawn part where you also have some thinning of the material.

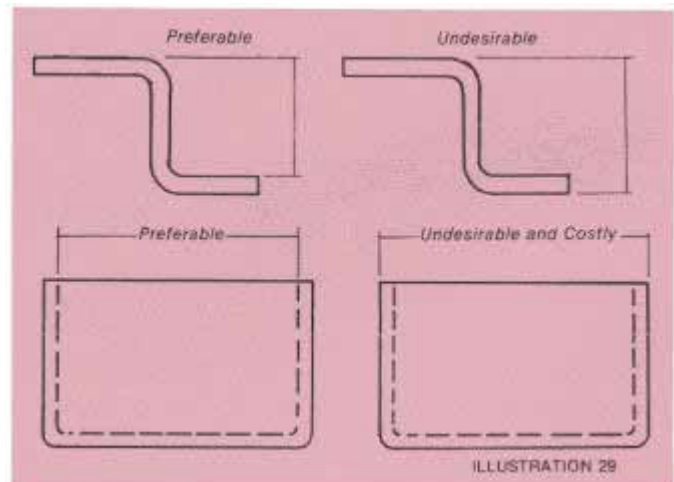

# EXTRUSIONS

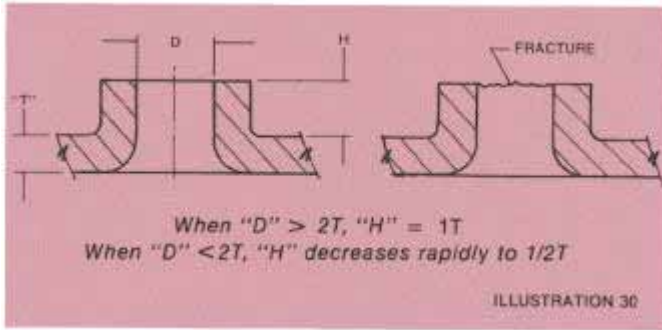

The function of an extrusion is to increase the material thickness to achieve more bearing surface or more threads in case of tapping. Maximum height to be expected is usually 1 material thickness. Anything over 1 material thickness will generally show a fracture or tearing condition, increasing in severity proportional to height increase. Decreasing "D" in Illustration will decrease "H" to about "1/2 T" in most cases.

# EMBOSSED STAMPINGS

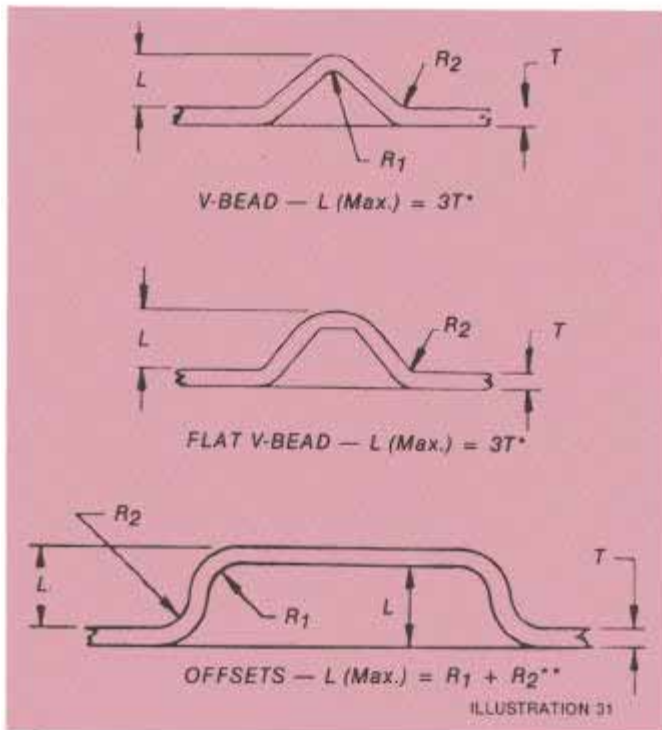

\*Reduce to 2T for commercial grades of steel, one-quarter hard tempers, and alloys of aluminum.

\*\*Reduce to .5 (R1 + R2) for commercial grades of steel, one-quarter hard tempers, and most alloys of aluminum.

Exceeding the maximum depth limits of embossed stamping for various metals increases rejects and stamping cost.

(The Precision Metalforming Association published portions of the above guidelines.)

# BURR REMOVAL

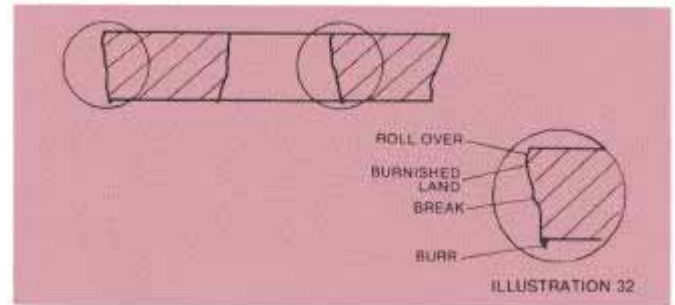

All metal stampings have varying degrees of burrs on the stamped edges. They are ragged, sometimes sharp edges of the stamped part.

The usual rule of thumb to follow on burrs is to allow for 10 percent of the stock.

Wrico normally includes tumbling or sanding on all parts when requested and whenever practical to do so. Special edge treatments are available at additional cost.

# FLATNESS

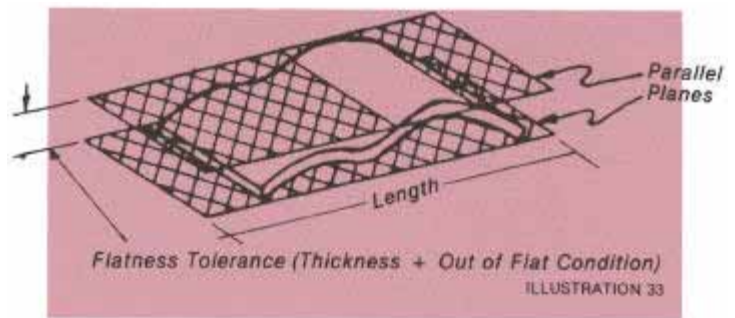

No stamping has perfectly flat surfaces. Flatness requirements beyond the tolerances that follow will increase the cost of your stampings.

If the surface length is from 0" to 1", allow +/- .005" tolerance. Over 4", allow .020" plus .004" for each inch of additional length.

Special flattening operations to better these tolerances are available at additional cost if so requested.

# SURFACE FINISH ON STAMPED PARTS

Dull, Semi Luster, Bright

The rule of thumb to follow here is the brighter the finished stamping, the higher the cost.

Raw metal stock varies in finish. Usually the finer (brighter) the finish, the higher its basic price is.

The stamping process may alter the metal finish greatly. So it is important to determine minimum finish requirements of the stamped part in order to maximize savings.



CAD/CAM Design



Presses from 20 to 400 Tons



CNC/FMS Laser Systems



CNC Robotic Welding Center



Process Controls Assure Quality

- High quality parts from simple stampings to value added components and complex assemblies.
- We blank, pierce, form, deburr, weld, stake, fasten, plate and paint parts up to 48" x 96" and 1/2" thick.
- State-of-the-art equipment to facilitate turn-key projects from prototypes to production.
- Presses from 20 to 400 tons to handle any size job.
- Process controls assure quality from prototype through production.
- Close tolerance, top quality, quick and dependable delivery at a competitive price.

## **Six Plants to Serve You Better**

**Central number 763-559-2288**

### **MINNESOTA**

2727 Niagara Lane N  
Minneapolis, MN 55447-4844  
FAX 763-553-7976  
763-559-2288  
[wricomn@wrico-net.com](mailto:wricomn@wrico-net.com)

### **TEXAS**

650 Industrial Blvd.  
Grapevine, TX 76051-3998  
FAX 817-488-0159  
817-488-6547  
[wricotx@wrico-net.com](mailto:wricotx@wrico-net.com)

### **NORTH CAROLINA**

10134 Industrial Dr.  
Charlotte, NC 28134-6516  
FAX 704-554-5651  
704-554-9060  
[wriconc@wrico-net.com](mailto:wriconc@wrico-net.com)

### **WISCONSIN**

N50 W13471 Overview Drive  
Menomonee Falls, WI 53051-7041  
FAX 262-781-4716  
262-781-4700  
[wricowi@wrico-net.com](mailto:wricowi@wrico-net.com)

### **FLORIDA**

10659 Rocket Blvd.  
Orlando, FL 32824-8590  
FAX 407-859-6473  
407-851-8342  
[wricofl@wrico-net.com](mailto:wricofl@wrico-net.com)

### **ARIZONA**

1310 N. Hobson Street  
Gilbert, AZ 85233-1207  
FAX 480-892-6363  
480-892-7800  
[wricoaz@wrico-net.com](mailto:wricoaz@wrico-net.com)